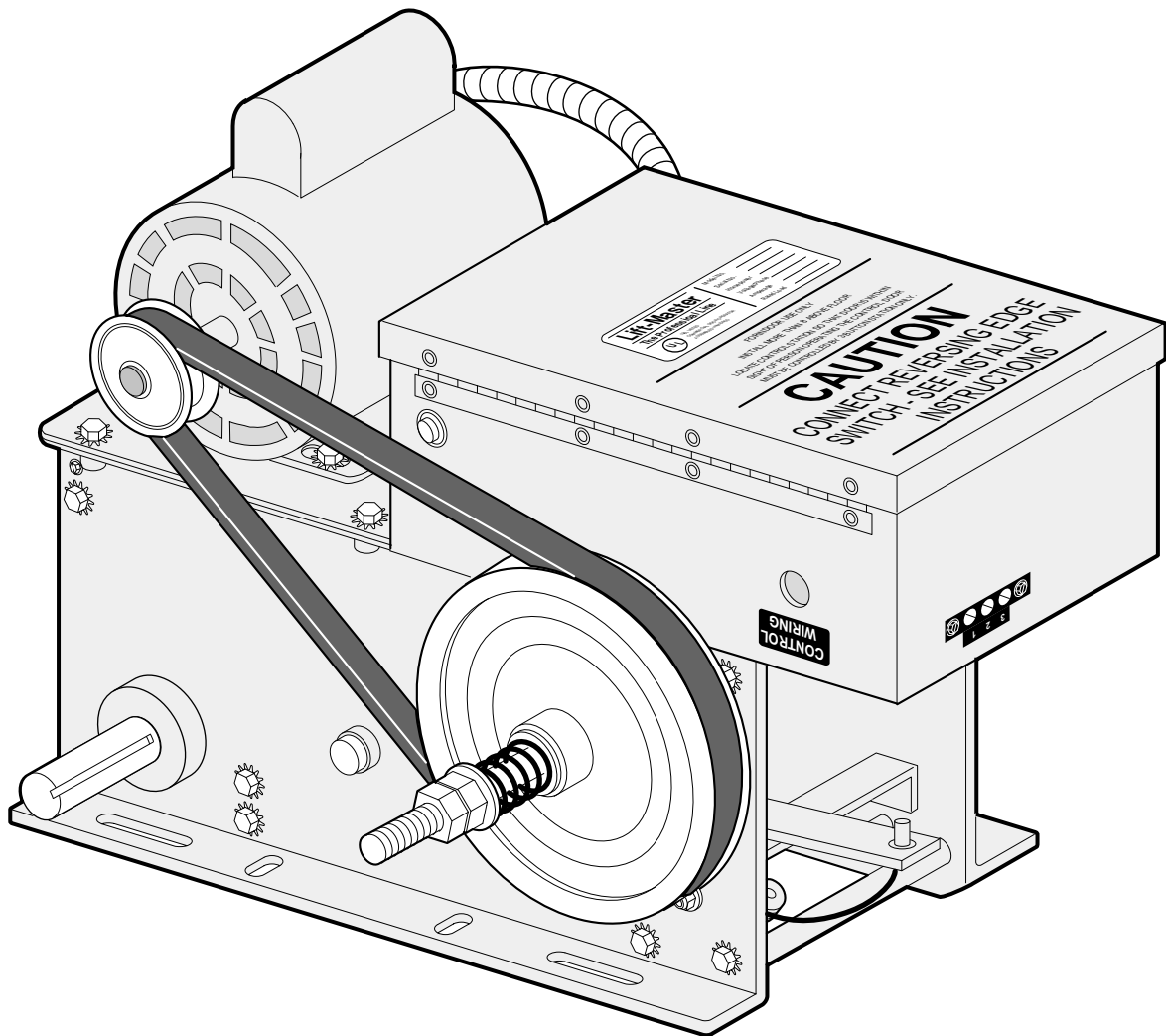


**OWNER'S MANUAL**  
**SERIES 2000**  
**MODEL HJ**  
**HEAVY DUTY**  
**BELT DRIVEN JACKSHAFT OPERATOR**



Serial # \_\_\_\_\_  
(located on electrical box cover)

Installation Date \_\_\_\_\_

Wiring Type \_\_\_\_\_



COMMERCIAL DOOR OPERATOR  
LISTED  
NOT FOR RESIDENTIAL USE

# SPECIFICATIONS

## MOTOR

**TYPE:** .....Continuous Duty  
**HORSEPOWER:** .....1/2, 1/2, 3/4 & 1 HP  
 Single or Three Phase  
**SPEED:** .....1725 RPM  
**VOLTAGE:** .....115/230 Single Phase  
 208-230/460 Three Phase  
**CURRENT:** .....See Motor Nameplate

## ELECTRICAL

**TRANSFORMER:** .....24VAC  
**CONTROL STATION:**.....3 Button  
 OPEN/CLOSE/STOP NEMA 1  
**WIRING TYPE:** .....B2 (Standard)  
 Momentary Contact to OPEN/CLOSE/STOP plus  
 Wiring for Sensing Device to Reverse and Auxiliary  
 Devices to Open and Close with Open Override  
**LIMIT ADJUST:** .....Linear Driven, Fully  
 Adjustable Screw Type Cams.

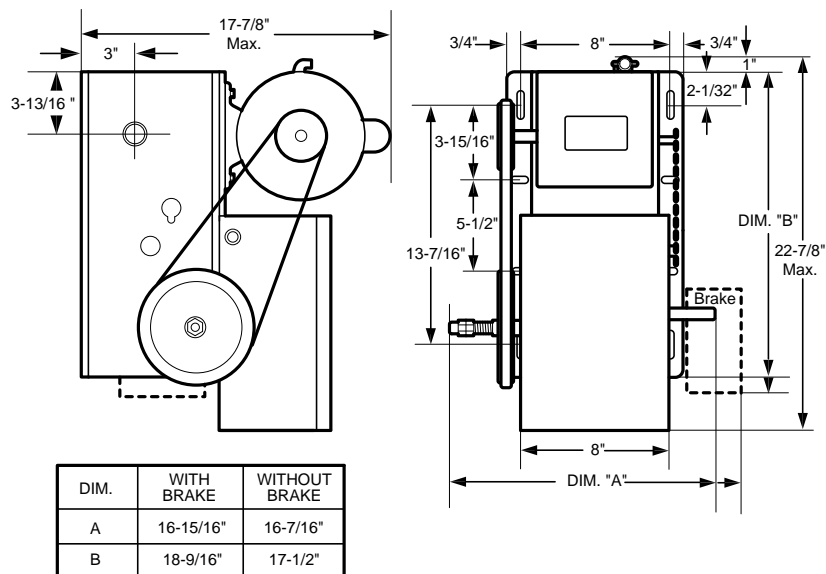
## MECHANICAL

**DRIVE REDUCTION:**  
**1st Reduction:**.....Heavy Duty (5L) V-Belt  
**2nd & 3rd Reductions:** ....#48 Chain and Sprockets  
**Output:**.....#50 Chain  
**OUTPUT SHAFT SPEED:** 47 R.P.M.  
**DOOR SPEED:** .....4" - 10" per sec.  
 (depending on door)  
**BEARINGS:** .....Heavy Duty Oil-Filled  
 Bronze. Ball Bearings on  
 Output Shaft  
**BRAKE:**.....Solenoid Drum Brake  
 (Optional)  
**HOIST WHEEL:**.....Standard

## SAFETY

**DISCONNECT:**.....Spring Loaded Floor Level  
 Disconnect Arm  
**CLUTCH:**.....Adjustable Friction Type  
**REVERSING EDGE:** .....(Optional)  
 Electric or Pneumatic Sensing Device attached to the  
 Bottom Edge of Door.  
**A REVERSING EDGE IS STRONGLY  
 RECOMMENDED FOR ALL COMMERCIAL  
 OPERATOR INSTALLATIONS. REQUIRED WHEN  
 THE 3 BUTTON CONTROL STATION IS OUT OF  
 SIGHT OF DOOR OR ANY OTHER CONTROL  
 (AUTOMATIC OR MANUAL) IS USED. SEE PAGE 8.**

## PHYSICAL Mounting Dimensions



# INSTALL OPERATOR



## CAUTION

TO AVOID DAMAGE TO DOOR AND OPERATOR, MAKE ALL DOOR LOCKS INOPERATIVE. SECURE LOCK(S) IN "OPEN" POSITION.  
IF THE DOOR LOCK NEEDS TO REMAIN FUNCTIONAL, INSTALL AN INTERLOCK SWITCH.  
DO NOT CONNECT ELECTRIC POWER UNTIL INSTRUCTED TO DO SO.



## WARNING

KEEP DOOR BALANCED. STICKING OR BINDING DOORS MUST BE REPAIRED. DOORS, DOOR SPRINGS, CABLES, PULLEYS, BRACKETS AND THEIR HARDWARE MAY BE UNDER EXTREME TENSION AND CAN CAUSE SERIOUS PERSONAL INJURY. CALL A PROFESSIONAL DOOR SERVICEMAN TO MOVE OR ADJUST DOOR SPRINGS OR HARDWARE.

### FOR SECTIONAL AND ROLLING TYPE DOORS

**CAUTION: AT LEAST 2 PERSONS AND A SAFE WORKING PLATFORM ARE REQUIRED FOR INSTALLATION**

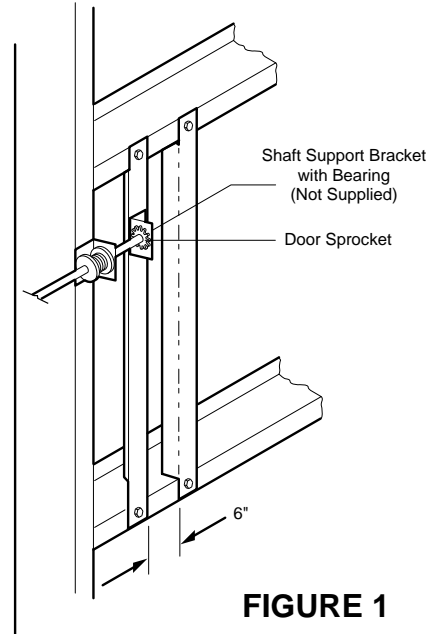
Check the operator name plate mounted on the electrical box to be sure the voltage, phase and h.p. are correct for your needs.

1. Close door.
2. For metal buildings, fasten 2"x2"x3/16" (or larger) angle iron frames to the building purlins. Retain 6" between frames. See Figure 1.
3. Place door sprocket and shaft support bracket (sectional door only) on door shaft as shown. Attach shaft support bracket to angle brace.

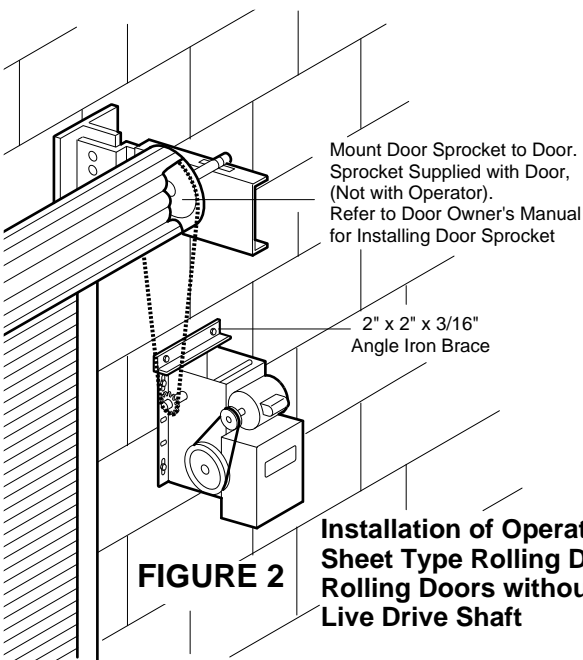
On concrete buildings, attach shaft support bracket to wall of building.

**NOTE 1: On concrete or block walls, install operator as shown in Figure 2.**

**NOTE 2: For standard rolling steel doors, install operator as shown in Figure 3. (If mounting to a steel building, make an angle iron mounting frame as shown in Figure 1).**

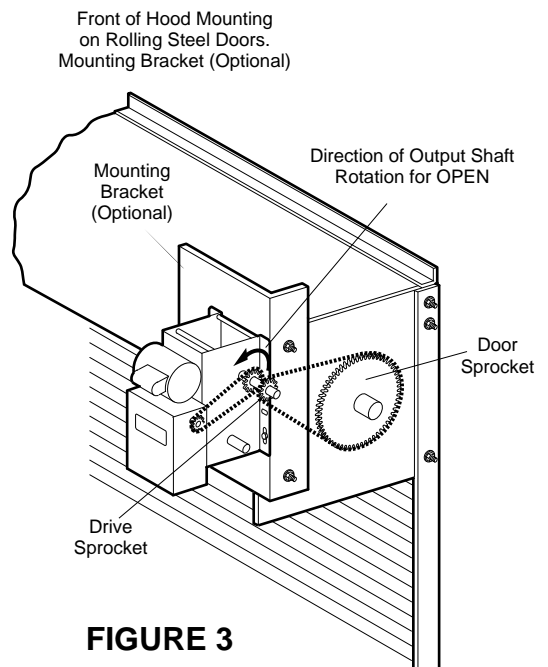


**FIGURE 1**



**FIGURE 2**

**Installation of Operator to Sheet Type Rolling Doors or Rolling Doors without Live Drive Shaft**



**FIGURE 3**

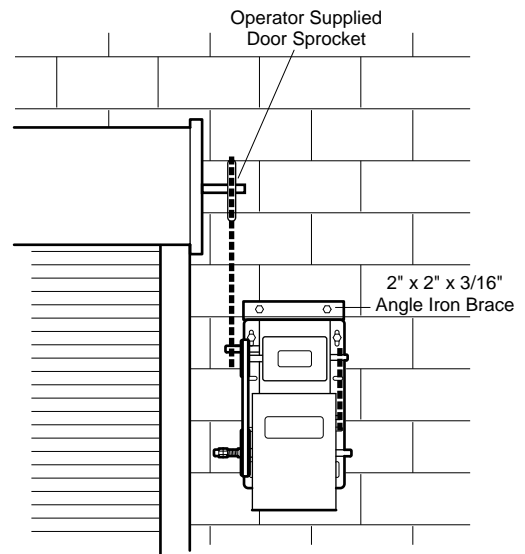
4. Place drive sprocket on appropriate side of operator. Do not insert key at this time.
5. Position roller chain over door sprocket and join ends together with master link.
6. Raise or lower operator until the chain is taut (not tight) as in Figure 4. Mark slotted holes to match operator frame.

**If drive sprocket is ABOVE door sprocket,** drill hole at the top of each slot.

**If drive sprocket is BELOW door sprocket,** drill hole at bottom of each slot.

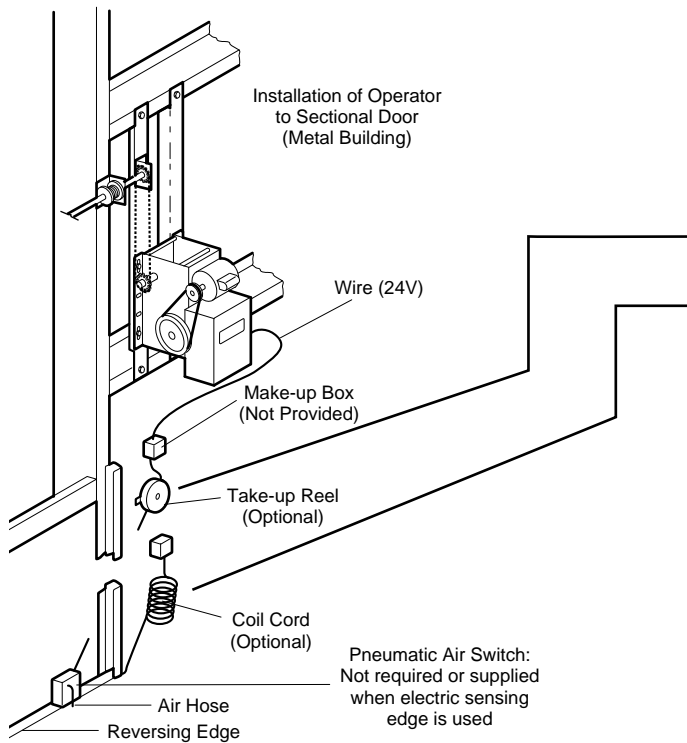
Placement of the drilled holes will allow for chain adjustment if necessary.

7. Make sure operator output shaft is parallel to door shaft and sprockets are aligned. When in position, secure operator with 3/8" bolts or concrete anchors as required.



**Installation of Operator to Standard Rolling Steel Doors.**

**FIGURE 4**



**REEL (OPTIONAL)**

Take-up reel should be installed 12" above top of door.

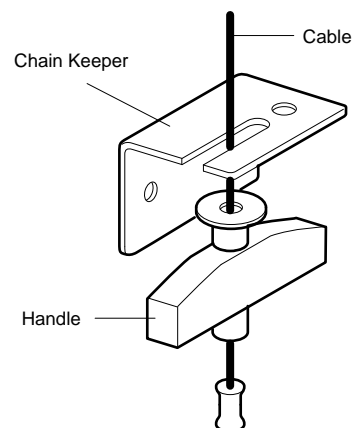
**COIL-CORD (OPTIONAL)**

Connect operator end of coil cord to junction box (not supplied) fastened to the wall approximately halfway up the door opening. (See Figure 5)

Electrician must hardwire junction box to the operator electric box in accordance with local codes.

**FOR OPERATORS WITH CHAIN HOISTS**

8. Place hand chain through eye bolt guides and around pocket wheel. Remove enough links so chain hangs approximately four feet above floor.
9. Uncoil disconnect cable and fasten chain keeper to the wall of building as shown in Figure 6. Adjust disconnect cable handpull and fender washer so chain keeper holds cable in position when cable is pulled as far as its travel permits.



**FIGURE 6**

## CONNECT OPERATOR TO POWER SUPPLY



### WARNING

DISCONNECT POWER AT THE FUSE BOX BEFORE PROCEEDING.

OPERATOR MUST BE PROPERLY GROUNDED AND CONNECTED IN ACCORDANCE WITH LOCAL ELECTRICAL CODES. NOTE: THE OPERATOR SHOULD BE ON A SEPARATE FUSED LINE OF ADEQUATE CAPACITY.

ALL ELECTRICAL CONNECTIONS MUST BE MADE BY A QUALIFIED INDIVIDUAL.



### CAUTION

TO AVOID DAMAGE TO DOOR AND OPERATOR, MAKE ALL DOOR LOCKS INOPERATIVE. SECURE LOCK(S) IN "OPEN" POSITION.

IF THE DOOR LOCK NEEDS TO REMAIN FUNCTIONAL, INSTALL AN INTERLOCK SWITCH.

REFER TO MASTER WIRING DIAGRAM.

MAKE CONNECTION THROUGH THE 1-1/16" DIA., LABELED HOLE.

DO NOT RUN CONTROL WIRES IN THE SAME CONDUIT AS THE POWER WIRES.

## INSTALL CONTROL STATION

Install the optional Reversing Edge before proceeding with the installation of the Control Station.

10. Complete the electrical connections to operator and control station (Refer to Control Connection Diagram, Pg. 20). Fasten the control station to the wall.

**FASTEN WARNING NOTICE BESIDE OR BELOW THE PUSH BUTTONS.**

11. Apply power to operator. Press either the OPEN or the CLOSE push button and observe direction of door travel. Press the STOP button.

If door does not move in the correct direction, check for improper wiring at control station or between operator and control station.

If the operator is single phase and control station wiring is correct, exchange the red and orange wires of the MOTOR CABLE at the motor end.

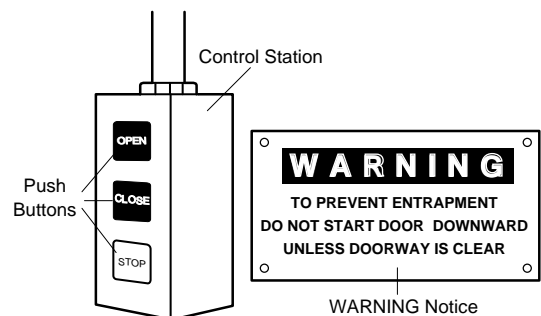
If operator is three phase and control station wiring is correct, exchange any two of the three incoming power leads.

If electrical problems persist, call our Toll Free number (1-800-528-6563) for assistance.



### WARNING

INSTALL THE CONTROL STATION WHERE THE DOOR IS VISIBLE, BUT AWAY FROM THE DOOR AND ITS HARDWARE. IF CONTROL STATION CANNOT BE INSTALLED WHERE DOOR IS VISIBLE, OR IF ANY DEVICE OTHER THAN THE CONTROL STATION IS USED TO ACTIVATE THE DOOR, A **REVERSING EDGE MUST BE INSTALLED ON THE BOTTOM OF THE DOOR.** FAILURE TO INSTALL A REVERSING EDGE UNDER THESE CIRCUMSTANCES MAY RESULT IN SERIOUS INJURY OR DEATH TO PERSONS TRAPPED BENEATH THE DOOR.



# ADJUST LIMITS

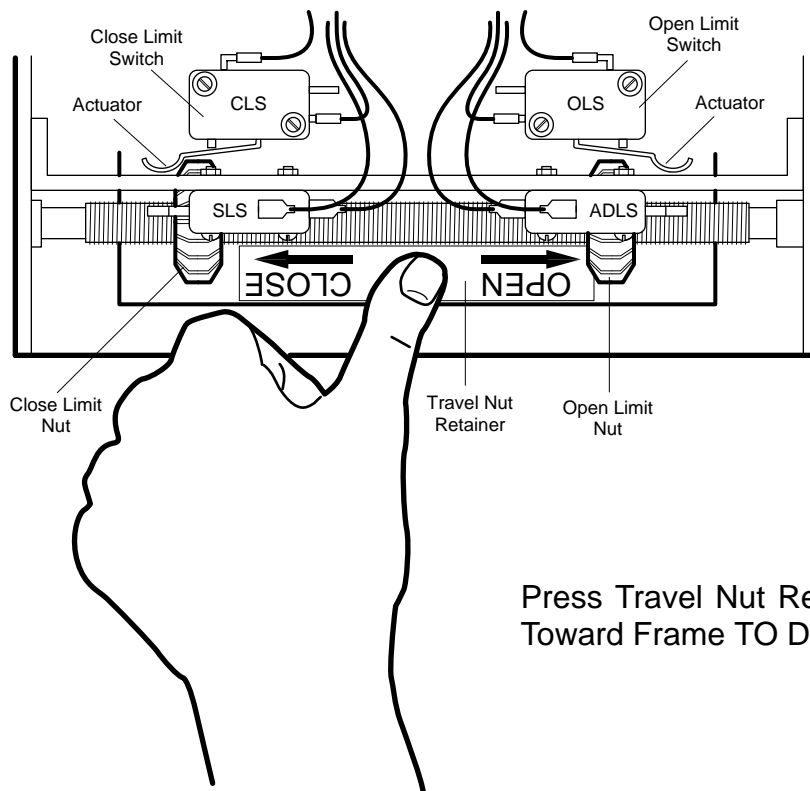


## WARNING

TO AVOID SERIOUS PERSONAL INJURY OR DEATH FROM ELECTROCUTION, DISCONNECT ELECTRIC POWER BEFORE MANUALLY MOVING LIMIT NUTS.

**MAKE SURE THE LIMIT NUTS ARE POSITIONED BETWEEN THE LIMIT SWITCH ACTUATORS BEFORE PROCEEDING WITH ADJUSTMENTS.**

1. Depress open limit switch. The operator should stop.
  2. To **increase** door travel, spin nut **away** from actuator. To **decrease** door travel, spin limit nut **toward** actuator.
  3. Adjust open limit nut so that door will stop in open position with the bottom of the door even with top of door opening.
  4. Repeat Steps 1 and 2 for close cycle. Be sure close limit actuator is engaged as door fully seats at the floor.
- If other problems persist, call our toll-free number for assistance - 1-800-528-6563.

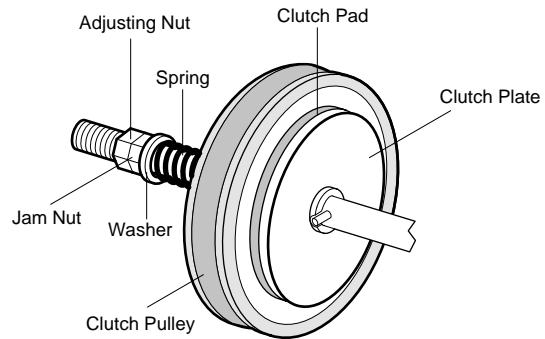


**MEMO:**

## ADJUST CLUTCH

Adjust clutch so that it is tight enough to open and close the door but will slip when the door meets an obstruction. Either loosen or tighten the clutch nut with 1/4 turn increments. The clutch will require periodic inspection and adjustment.

**CAUTION:** The adjustable friction clutch is **NOT** an automatic reversing device. An electric or pneumatic reversing edge can be added to bottom edge of door if desired.



## CONNECT REVERSING EDGE DEVICE (OPTIONAL)



### WARNING

IF CONTROL STATION CANNOT BE INSTALLED WHERE DOOR IS VISIBLE, OR IF ANY DEVICE OTHER THAN THE CONTROL STATION IS USED TO ACTIVATE THE DOOR, A REVERSING EDGE **MUST BE INSTALLED ON THE BOTTOM OF THE DOOR**. FAILURE TO INSTALL A REVERSING EDGE UNDER THESE CIRCUMSTANCES MAY RESULT IN SERIOUS PERSONAL INJURY OR DEATH TO PERSONS TRAPPED BENEATH THE DOOR.

The operator has been pre-wired to accept connection of a reversing edge device (Figure 5, page 4). Connect the normally open contacts to terminals T3 and T5 on the low voltage terminal block. A cut-off switch will de-activate the safety device during the last few inches of the door's downward travel.

**MAINTENANCE SCHEDULE:** Check at the intervals listed in the following chart.

ITEM	PROCEDURE	EVERY 3 MONTHS	EVERY 6 MONTHS	EVERY 12 MONTHS
Drive Chain	Check for excessive slack. Check & adjust as required. Lubricate.*	●		✓
Sprockets	Check set screw tightness	●		✓
Clutch	Check & adjust as required		●	✓
Belt	Check condition & tension		●	✓
Fasteners	Check & tighten as required		●	✓
Manual Disconnect	Check & Operate		●	✓
Bearings & Shafts	Check for wear & lubricate	●		✓

\* Use SAE 30 Oil (Never use grease or silicone spray).

✓ Repeat ALL procedures.

■ Do not lubricate motor. Motor bearings are rated for continuous operation.

■ Do not lubricate clutch or V-belt.

■ Inspect and service whenever a malfunction is observed or suspected.

■ **CAUTION: BEFORE SERVICING, ALWAYS DISCONNECT OPERATOR FROM POWER SUPPLY.**

### HOW TO ORDER REPAIR PARTS

OUR LARGE SERVICE ORGANIZATION  
SPANS AMERICA  
INSTALLATION AND SERVICE INFORMATION  
ARE AVAILABLE 6 DAYS A WEEK  
CALL OUR TOLL FREE NUMBER - 1-800-528-6563  
HOURS 7:00 TO 3:30 p.m. (Mountain Std. Time)  
MONDAY Through SATURDAY

WHEN ORDERING REPAIR PARTS  
PLEASE SUPPLY THE FOLLOWING INFORMATION:  
**PART NUMBER DESCRIPTION MODEL NUMBER**

ADDRESS ORDER TO:  
THE CHAMBERLAIN GROUP, INC.  
Electronic Parts & Service Dept.  
2301 N. Forbes Blvd., Suite 104  
Tucson, AZ 85745



# 1A3989, 1A4045, 1A4046 & 1A4047 BRAKE INSTALLATION & ASSEMBLY PARTS



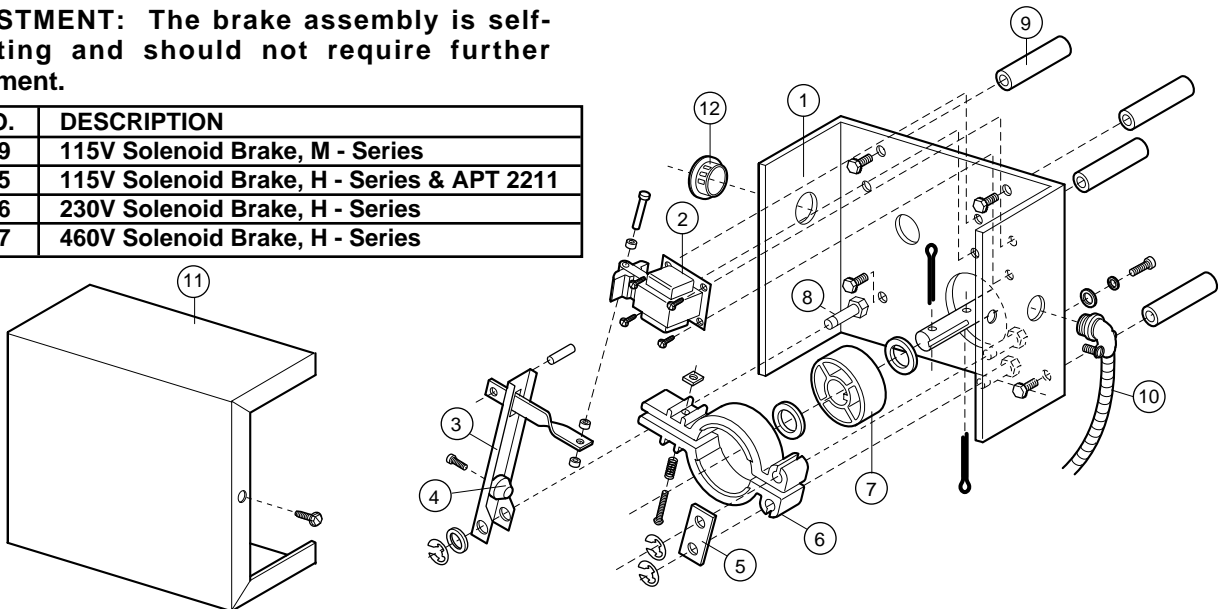
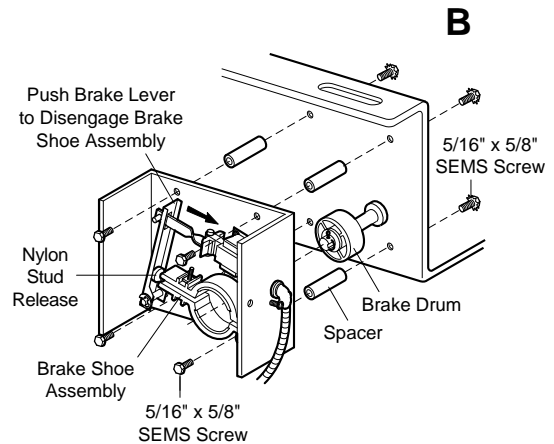
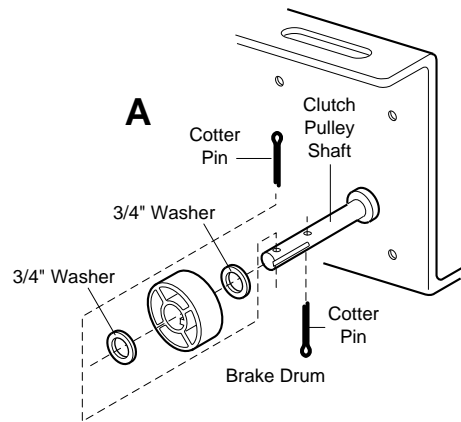
## WARNING

**TO AVOID SERIOUS PERSONAL INJURY OR DEATH FROM ELECTROCUTION, DISCONNECT ELECTRICAL POWER TO OPERATOR BEFORE PROCEEDING.**

1. Install brake drum on clutch pulley shaft as illustrated in Fig. A.
2. Attach the four spacers provided to back of brake pulley assembly housing using four 5/16 x 5/8 sems screws (Fig. B).
3. Push brake lever engaging nylon stud release between brake shoes and align brake drum between brake shoe assembly (Fig. B).
4. Adjust spring loaded bolt on brake shoe assembly so that spring is compressed to 1".
5. Mount brake assembly housing to operator frame using the four spacers and 5/16 x 3/8 sems screws (See Fig. B).
6. Remove plug from 7/8" hole in electrical box and attach conduit assembly.
7. Connect wires per master wiring diagram, (See "brake optional").
8. Reconnect power to the operator.
9. Test for proper brake operation and replace brake cover.

**ADJUSTMENT:** The brake assembly is self-adjusting and should not require further adjustment.

KIT NO.	DESCRIPTION
1A3989	115V Solenoid Brake, M - Series
1A4045	115V Solenoid Brake, H - Series & APT 2211
1A4046	230V Solenoid Brake, H - Series
1A4047	460V Solenoid Brake, H - Series

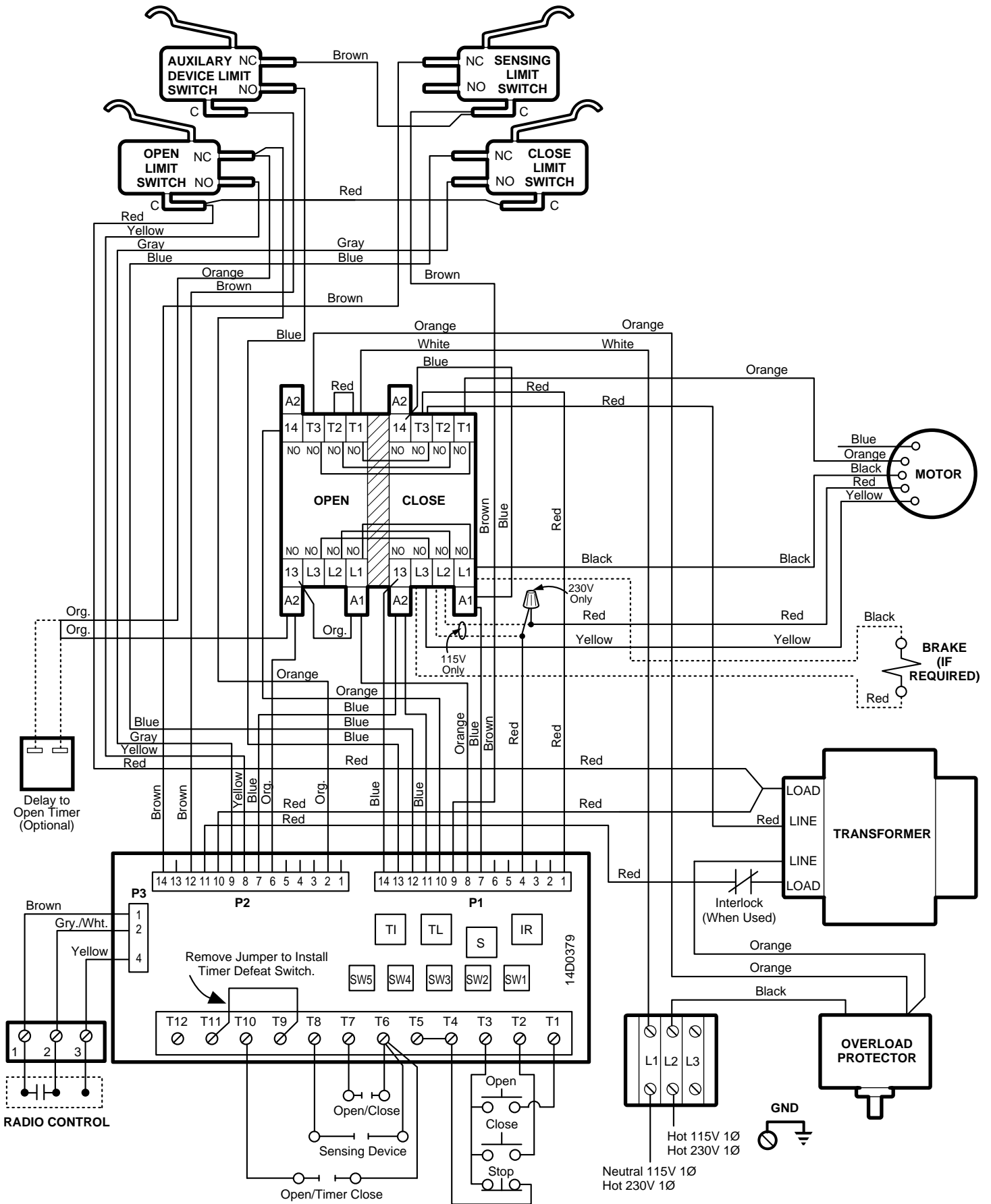


### REPAIR PARTS FOR BRAKE ASSEMBLY

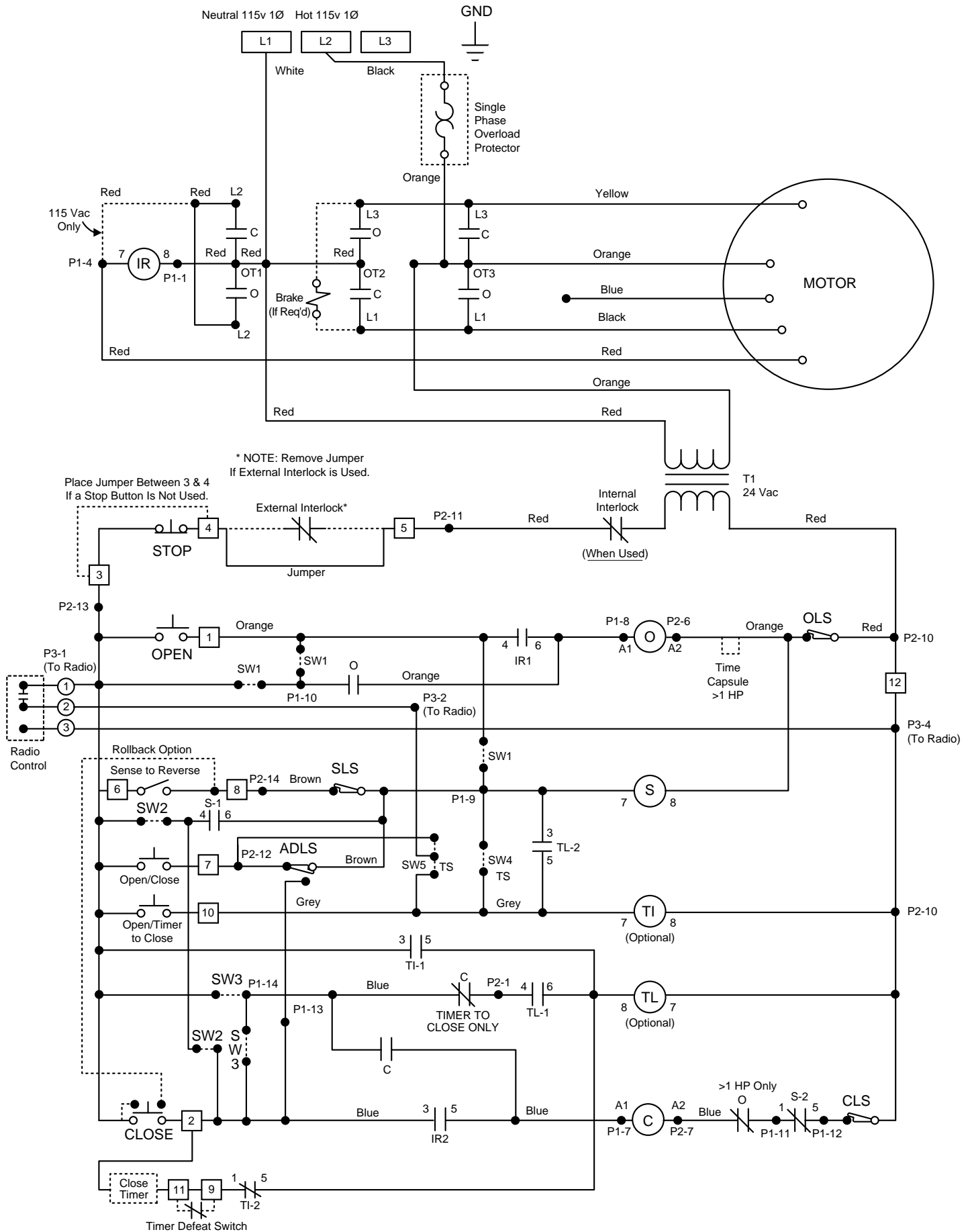
ITEM	PART NO.	DESCRIPTION & QUANTITY
1	17D111	Brake Box (1)
2	204B118	Solenoid 115V (1)
	204B118-1	Solenoid 230V (1)
	204B118-2	Solenoid 460V (1)
3	113B49	Brake Lever, Pivot (1)
4	179A46	Brake Release Stud
5	142A143	Brake Stud Plate (1)

ITEM	PART NO.	DESCRIPTION & QUANTITY
6	1B4421	Brake Shoe Assy. (2)
7	60B31	Brake Drum (1)
8	179B45	Brake Pivot Stud (3)
9	184A111	Brake Spacer (4)
	1B3933	Conduit Assy. M-Series (1)
	1B4044	Conduit Assy. H-Series (1)
11	31D387	Cover (1)
12	31A388	Dome Plug (1)

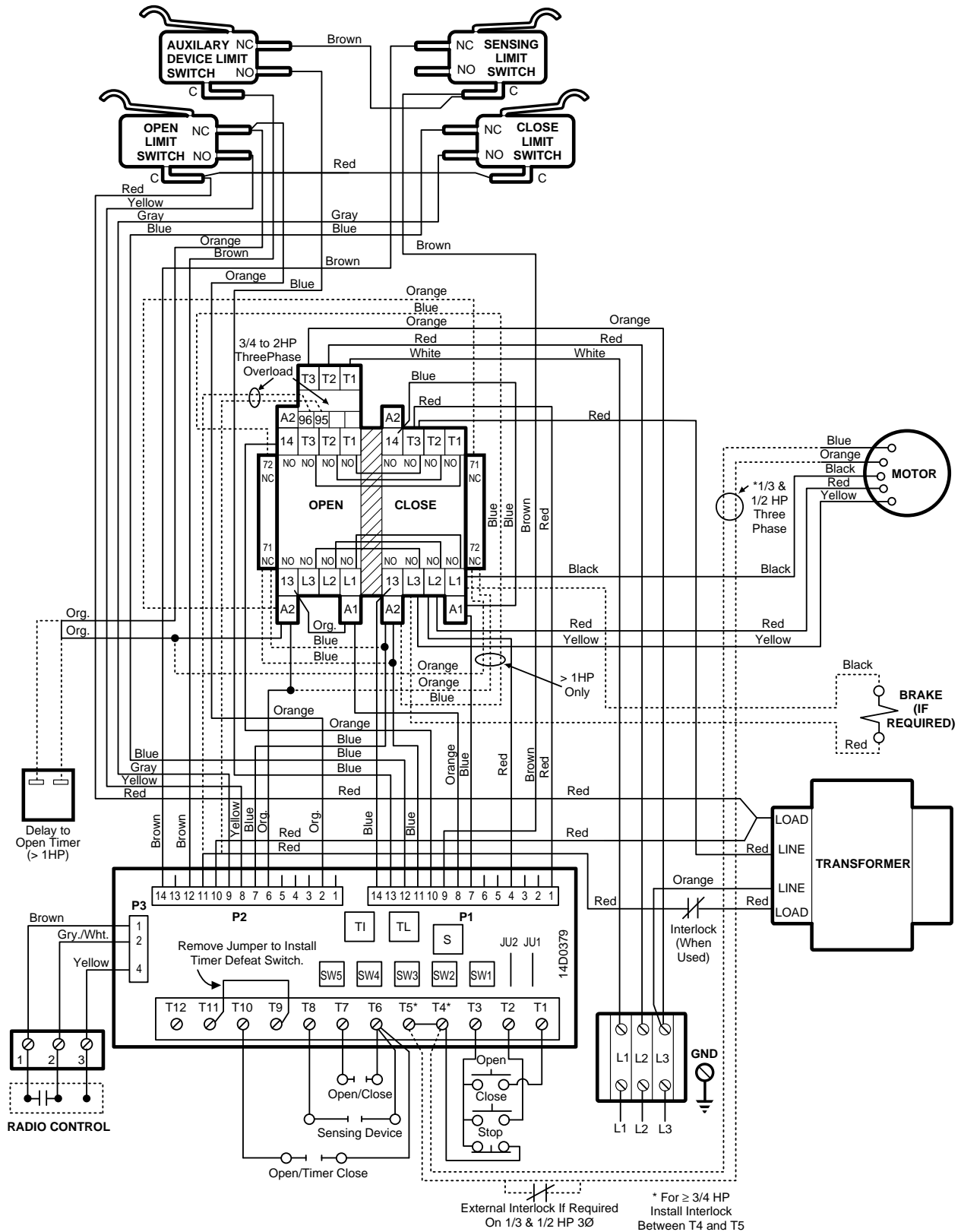
# HJ SINGLE PHASE WIRING DIAGRAM (For P.C. Board #14D0379)



# HJ SINGLE PHASE SCHEMATIC DIAGRAM (For P.C. Board #14D0379)



# HJ THREE PHASE WIRING DIAGRAM (For P.C. Board #14D3079)



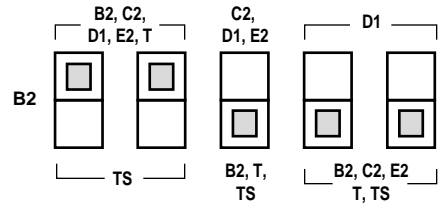


# WIRING KITS

**TYPE      STATION**

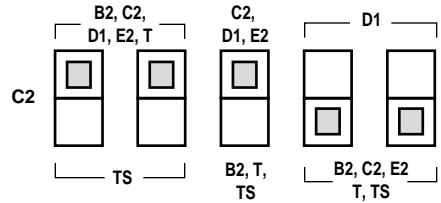
**B2            3 Button**

Function: Momentary contact to open, close and stop, plus wiring for sensing device to reverse and auxiliary devices to open and close with open override.



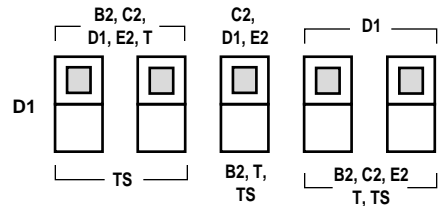
**C2            3 Button**

Function: Momentary contact to open and stop with constant pressure to close, open override plus wiring for sensing device to reverse.



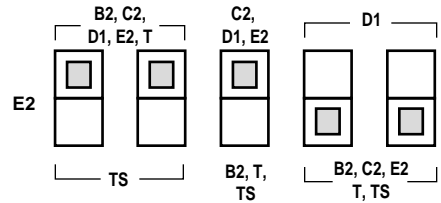
**D1            2 Button**

Function: Constant pressure to open and close with wiring for sensing device to stop.



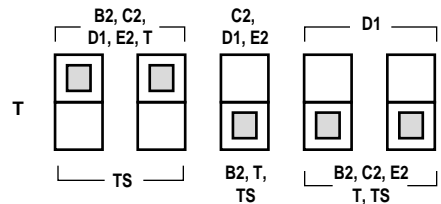
**E2            2 Button**

Function: Momentary contact to open with override and constant pressure to close. Release of close button will cause door to reverse (roll-back feature) plus wiring for sensing device to reverse.



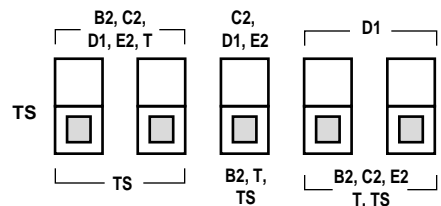
**T\*            3 Button**

Function: Momentary contact to open, close and stop, with open override and timer to close. Open button can be connected to activate timer if desired. Auxiliary controls can be connected to open and activate timer to close or to open and close without activating timer. If timer has been activated, reinitiation of the timer to close circuit will recycle the timer. Includes wiring for sensing devices to reverse which will NOT activate time.



**TS\*          3 Button**

Function: Momentary contact to open, close and stop with open override and timer to close. EVERY device that causes door to open will activate timer to close including sensing device to reverse. Timer may be deactivated until next opening signal is received by depressing stop button after door has reached open position or permanently by use of optional timer defeat switch. If timer has been activated, reinitiation of open circuit will recycle the timer.



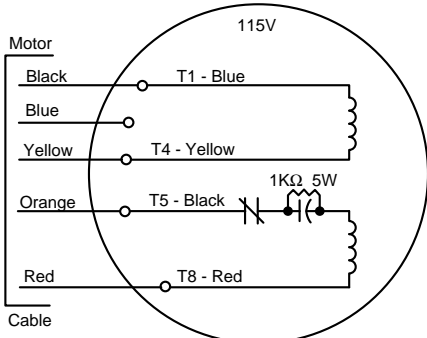
**NOTE:**

1. External interlocks may be used with all wiring types.
2. Auxiliary devices are any devices that have only one set of contacts. Examples are: photocell, loop detector, pneumatic or electrical treadles, residential radio controls, one button stations, pull cords, etc.
3. Open override means that the door may be reversed while closing by activating an opening device without the need to use the stop button first.

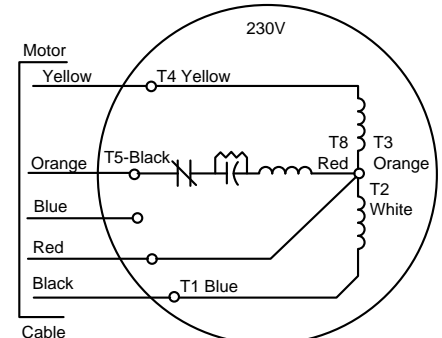
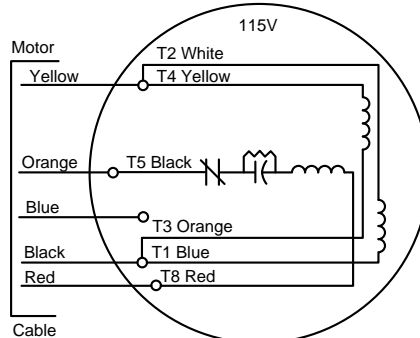
# NEMA MOTOR WIRING DIAGRAMS

## SINGLE VOLTAGE

1/3 & 1/2 H.P. 115 V only

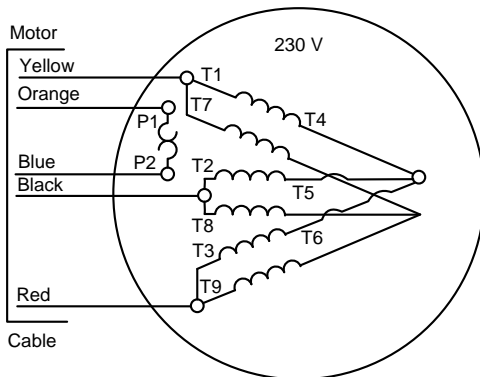


## 1 PHASE

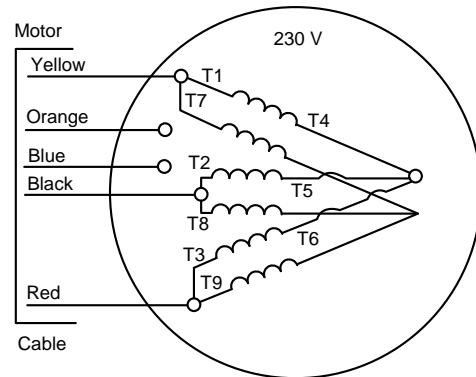


## 3 PHASE

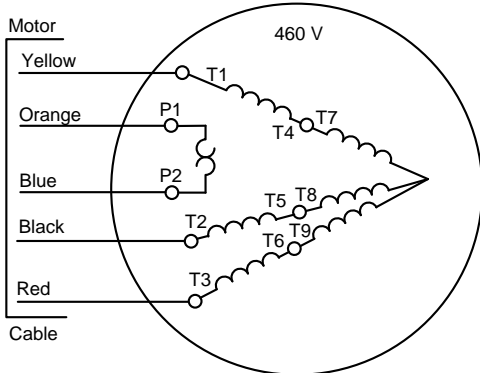
1/3 & 1/2 H.P.



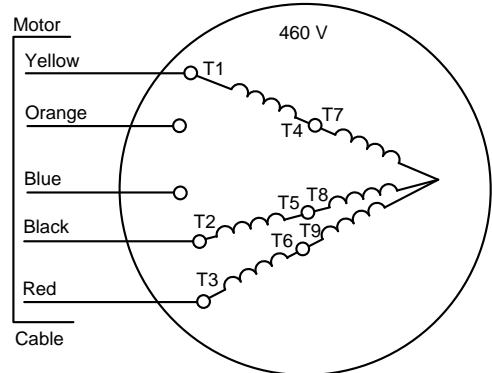
3/4 H.P. & OVER



1/3 & 1/2 H.P.

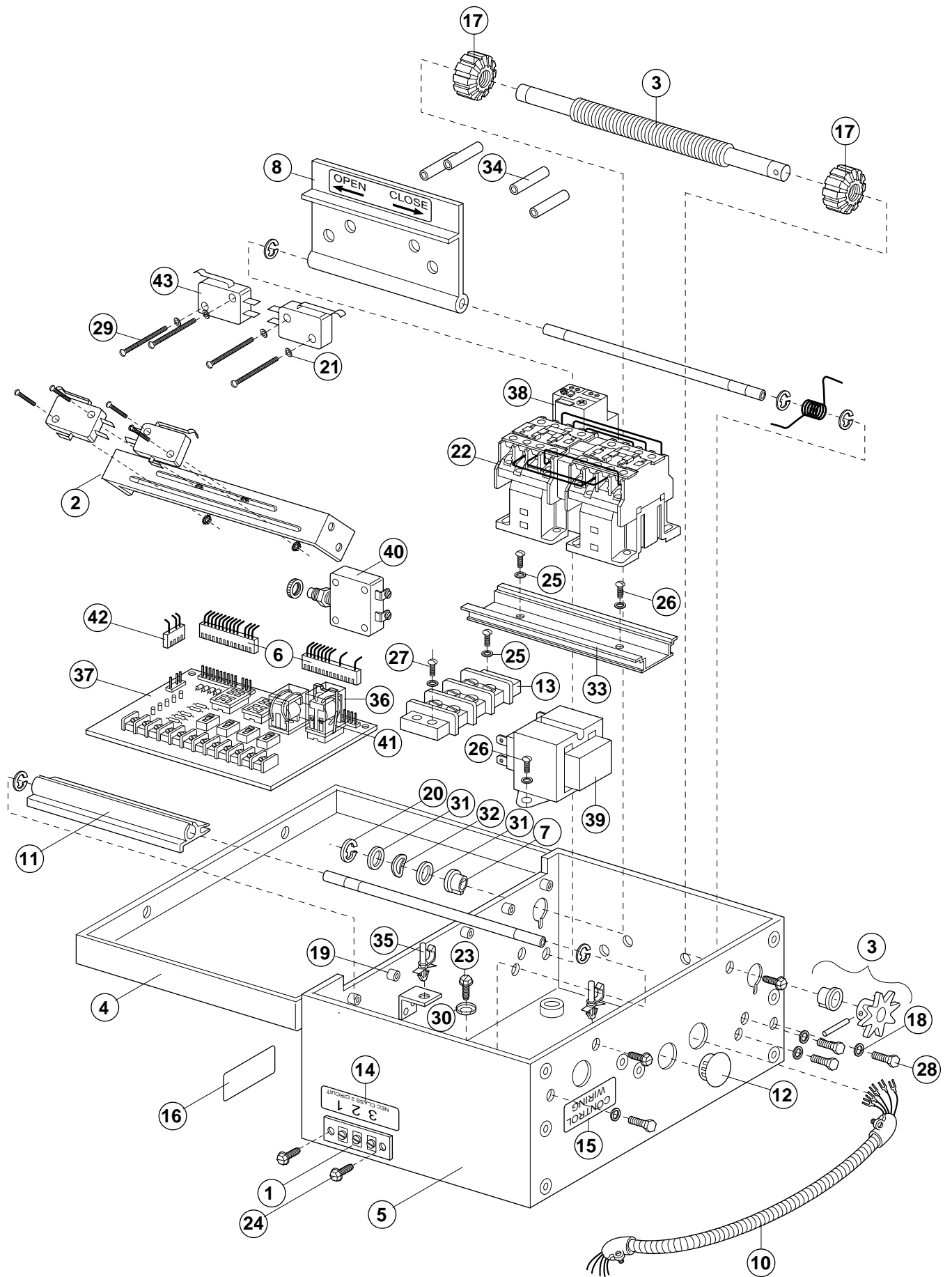


3/4 H.P. & OVER



○ DENOTES WIRENUT CONNECTION

# ILLUSTRATED PARTS – HT & HJ SERIES ELECTRICAL BOX





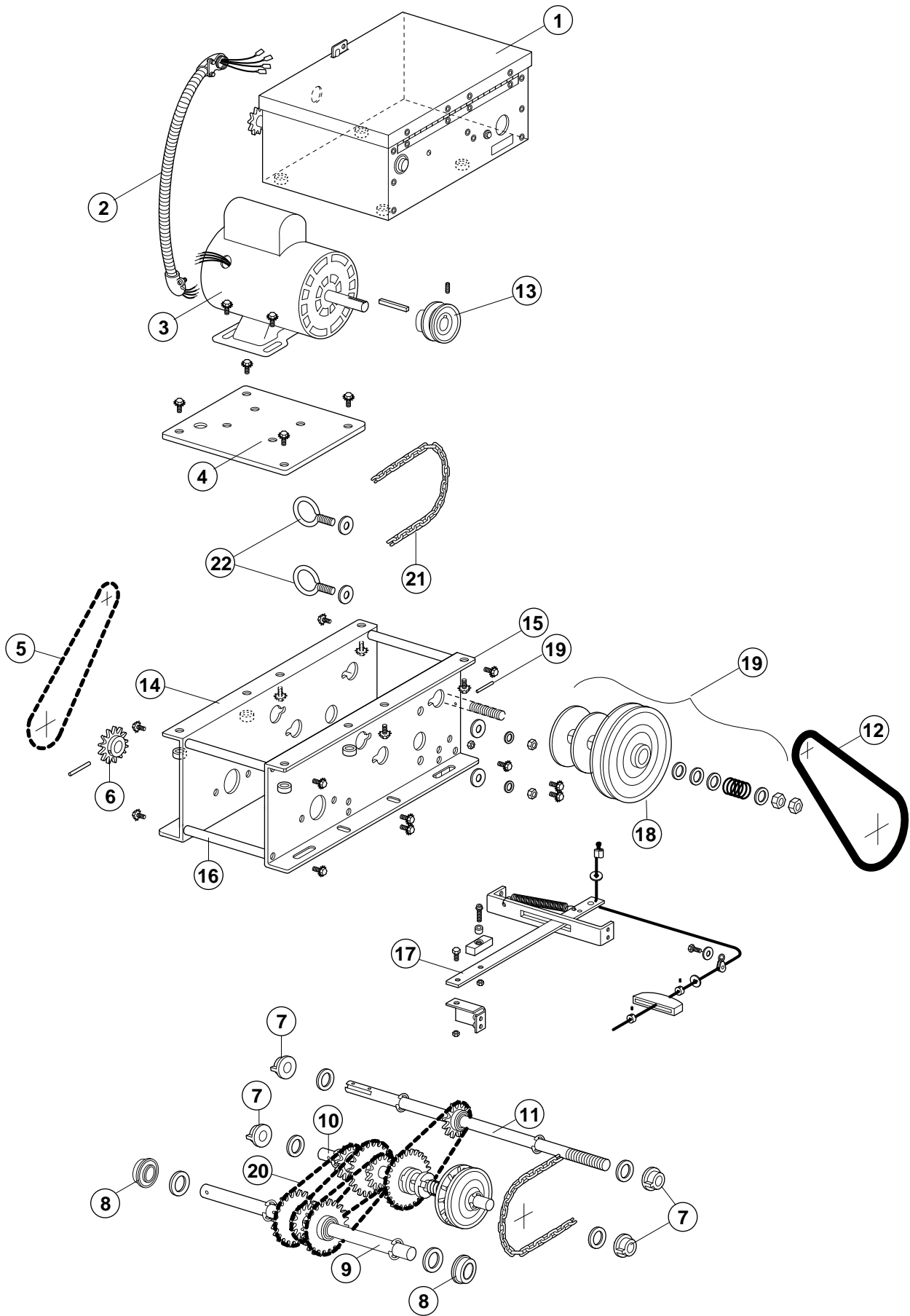
# REPAIR PARTS – HT & HJ SERIES ELECTRICAL BOX

ITEM NO.	PART NO.	QTY	DESCRIPTION
1	1B3727	1	Terminal Assy. 3-Lug
2	41K4304	1	Switch Bracket Assy. (Aux. & Sensing)
3	1B3796	1	Ltd. Shaft-Sprocket Assy.
4	1B3938	1	Cover & Hinge Assy.
5	1C3937	1	Electric Box Assy.
6	1D4017	1	Wire Harness
7	11A012	1	Flanged Sleeve Bearing
8	41K4303	1	Limit Bracket (Adj.) Kit
10	1B4062	1	Motor Cable Assy.
11	41K4305	1	PCB Holder Assy. Kit
12	31A388	1	Dome Plug
13	203A177	1	Terminal Strip 3 Lug
14	132A2011	1	Label - Class 2 NEC Circuit
15	132B1931	1	Control Wiring Label
16	132B1930	1	Label - Power Wiring
17	133A182	2	Limit Nut 1/2"
18	216A10	7	Washer #6 Internal Lock
19	157A84	4	Rivet
20	158A49	1	Retaining Ring 3/8
21	216A43	4	Washer #4 Internal Lock
22	160C86	1	Reversing Contactor
23	171A220	1	Screw #8F 1/2 SL Hex Green
24	171A311	4	S.T. SCR #8TF 3/8" Hex/Washer
25	216A140	6	Washer #8 Lock-Split
26	171A337	4	Machine Screw 8-32 x 1/2" Hex
27	171A339	2	Machine Screw 8-32 x 3/4" Sl. Pan
28	171A386	7	Screw 6-32 x 1/2" - Hex Head
29	171A411	4	Screw 4/40 x 1-1/2" Pan Head
30	216A149	1	Washer #8 Terminal Cup
31	216A184	2	Thrust Washer
32	216A191	1	Washer, Spring Curved
33	183B139	1	DIN Rail - 4-3/4"
34	184A109	4	Spacer - Stand Off - Round
35	184A112	2	PCB Stand Off
43	180B133	2	Limit Switch

ITEM	PART NO.	DESCRIPTION	QUANTITY															
			DESCRIPTION MOTOR P/N	1/3 HP, 115V, 1 PHASE 123D121	1/3 HP, 230V, 1 PHASE 123D121	1/3 HP, 230V, 3 PHASE 123D117	1/3 HP, 460V, 3 PHASE 123D117	1/2 HP, 115V, 1 PHASE 123D122	1/2 HP, 230V, 1 PHASE 123D122	1/2 HP, 230V, 3 PHASE 123D118	1/2 HP, 460V, 3 PHASE 123D118	3/4 HP, 115V, 1 PHASE 123D123	3/4 HP, 230V, 1 PHASE 123D123	3/4 HP, 230V, 3 PHASE 123D119	3/4 HP, 460V, 3 PHASE 123D119	1 HP, 115V, 1 PHASE 123D124	1 HP, 230V, 1 PHASE 123D124	1 HP, 230V, 3 PHASE 123D120
M		Motor	1	1	1	1	1	1	1	1	1	1	1	1	1	1	1	1
36	160B83	Relay 115V	1					1							1			
	160B84	Relay 230V		1					1				1				1	
37	1C4198	PCB 1 Phase	1	1				1	1					1	1			
	1C4197	PCB 3 Phase			1	1				1	1			1	1			1
38	160B73-01	Overload 1-1.6 A*												1				
	160B73-02	Overload 1.6-2.5A*																1
	160B73-03	Overload 2.5 - 4A*											1					1
39	204C122-08	Transformer 115V	1					1						1				
	204C122-09	Transformer 230V		1	1				1	1			1	1			1	1
	204C122-07	Transformer 460V					1							1				1
40	180B159-0	Overload 3.5A		1														
	180B159-1	Overload 5A							1									
	180B159-2	Overload 7A	1										1					
	180B159-3	Overload 8A															1	
	180B159-4	Overload 10A						1										
	180B159-5	Overload 15A														1		
	180B159-9	Overload 12A																1
41	29A132	Relay Clip	1	1				1	1					1	1			
42	1B4048	Radio Cntrl Harness	1	1	1	1	1	1	1	1	1	1	1	1	1	1	1	1

REMARKS: \*Overload to be set at 115% maximum of motors rated current.

# ILLUSTRATED PARTS – OPERATOR MODEL HJ



## REPAIR PARTS – MODEL HJ

ITEM NO.	PART NO.	QTY.	DESCRIPTION
1		1	Electrical Box Assy. (See detail)
2	1B4062	1	Motor Cable Assy.
3	Motor	1	See Chart
4	1C3972	1	Motor Plate Assy.
5	1A3971	1	Chain Assy. (49 Pitches)
6	81C149	1	Sprocket-Hub Assy. 1"
7	41K4306	2	Oil Lite Brg. 3/4" I.D. Kit
8	41K4498	2	Ball Bearing Kit - 1" I.D.
9	1C3690-1	1	Output Shaft Assy.
10	1C3687-1	1	Shaft Assy. - Hoist
11	1C3691-2	1	Shaft Assy. - Pulley
12	20B9	1	V-Belt 5L
13	144B37	1	Pulley 2-1/2" 5L
14	59D48	1	Frame - Jack - Right
15	59D48-1	1	Frame - Jack - Left
16	184B97	4	Spacer
17	41K4346	1	Disconnect Arm Assy.
18	144C38	1	Pulley 8" - 5L
19	41K4301	1	Clutch Assy. Kit
20	1A3741	4	Chain Assy. (41 Pitches)
21	22A14	Varies	Unwelded Hand Chain
22	171A410	2	Eye Bolt 1"

# CONTROL CONNECTION DIAGRAM



**ATTENTION: The 3-Button Control Station provided must be connected for operation.**

