



The range

230V A.C. Barriers

- G4041** Automatic barrier in galvanized and painted steel with 230V A.C. operator with control panel.
- G4041I** Automatic barrier in brushed AISI 304 stainless steel with 230V A.C. operator with control panel.

230V A.C. Electronics

- ZG5** Plus control panel.
- ZG6** Basic control panel.
- RSE** Function management control board for ZG5.

24V D.C. Barriers

- G4040** Automatic barrier in galvanized and painted steel with 24V D.C. operator with control panel.
- G4040I** Automatic barrier in satin-finish AISI 304 stainless steel with 24V D.C. operator with control panel.

24V D.C. Electronics

- ZL38** Control board fitted to take Came radio frequency cards.
- LB38** Emergency battery card.

Made in Italy



For its quality processes management Came Cancelli Automatici is ISO 9001:2000 certified, and for its environmental management it is ISO 14001 certified. Came designs and manufactures entirely in Italy.

Technical features

Type	G4041 / G4041I	G4040 / G4040I
Protection rating	IP54	IP54
Power supply (V)	230 A.C 50/60Hz	230 A.C 50/60Hz
Motor power supply (V)	230 A.C 50/60Hz	24 D.C.
Power (W)	250	300
Current draw (A)	2,2	15
Reduction ratio (i)	1/202	1/202
Max torque (Nm)	220	600
Opening time (s)	4	2 ÷ 6
Duty cycle (%)	30	intensive use
Operating temperature (°C)	-20 ÷ +55	-20 ÷ +55
Cabinet colour	Grey textured metal finish 0530837	Grey textured metal finish 0530837
Cover colour	RAL 9006	RAL 9006

● 230V A.C. ● 24V D.C.

General information

Composition of the bar	Max opening clearance	m	ft
Bar with shock-resistant profile		3,75	12,3
Bar with shock-resistant profile and luminous cord		3,75	12,3
Bar with rack		3,75	12,3
Bar with luminous cord and rack		3,75	12,3
Bar with shock-resistant profile and mobile barrier support		3,75	12,3
Bar with shock-resistant profile, luminous cord and mobile barrier support		3,75	12,3
Bar with rack and mobile barrier support		3,50	11,5
Bar with luminous cord, rack and mobile barrier support		3,50	11,5

Dimensions

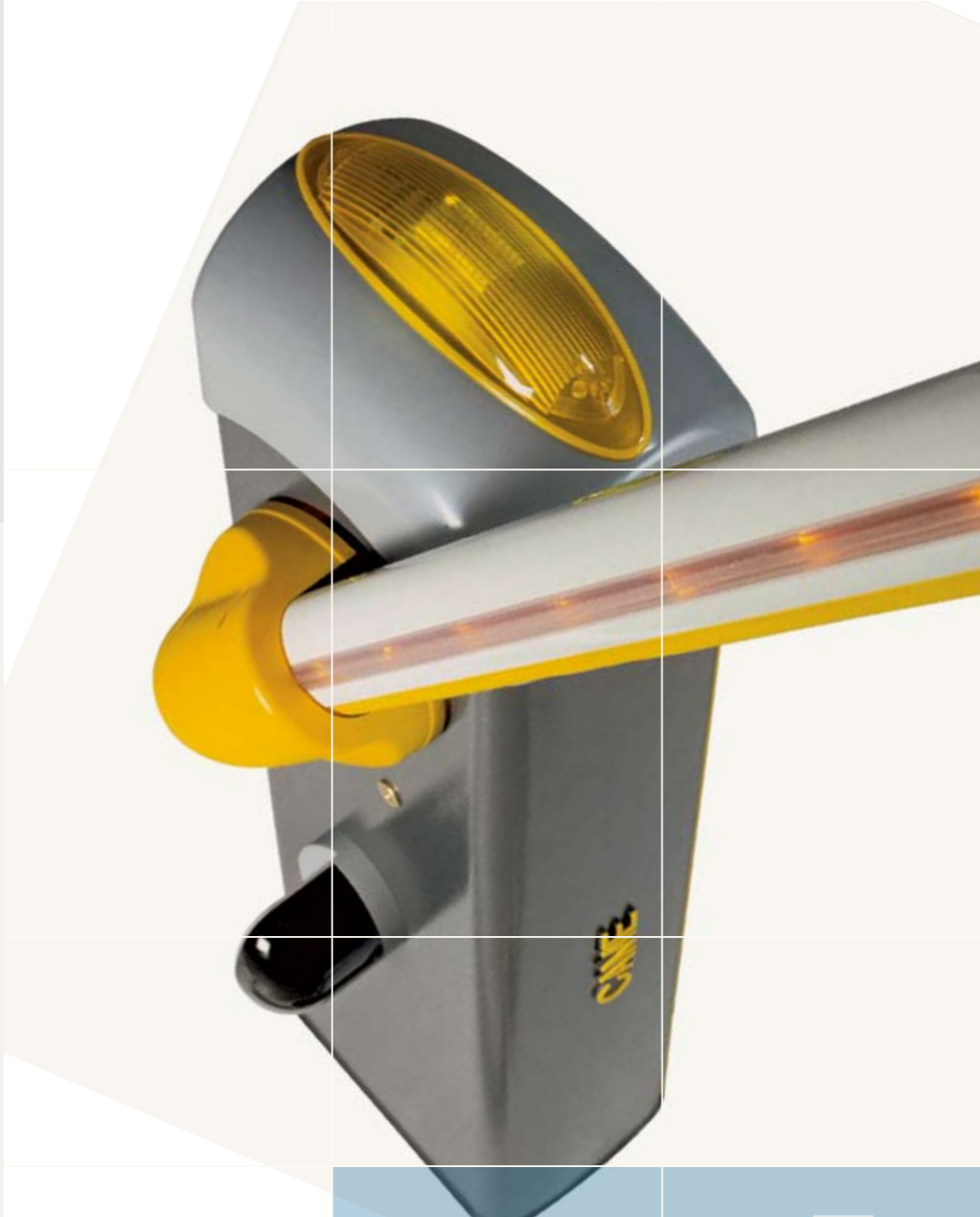
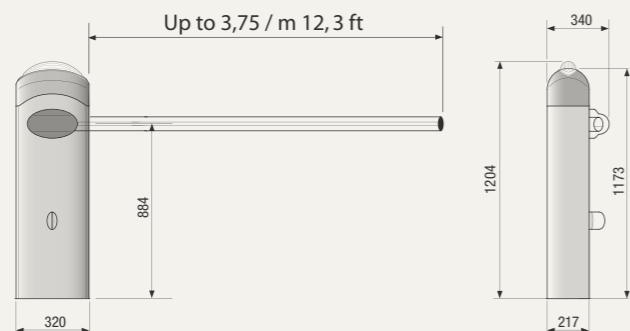

new Gard4

Automatic road barriers for passages of up to 3.75 m / 12.3 ft



A new concept of automatic barrier

Innovation and design for all-inclusive safety: these are the most recent additions to the Gard barrier line family. Soft contours and rounded corners to counteract the "sail effect" for a barrier that incorporates perfectly into a diversity of installation settings.



Came cancelli automatici s.p.a.

via Martiri della Libertà, 15
31030 Dosson di Casier
Treviso - Italy

www.came.it - info@came.it

© Came DEF5620 06/2007

The data and information shown in this catalogue are subject to change without the obligation to give prior notice by Came cancelli automatici S.p.A.

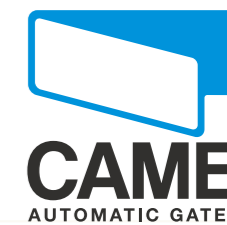

Gard4

230V 24V

Automatic road barriers

Designed for a range of large openings up to 3,75 m / 12,3 ft, the new Gard barriers are the ideal solution for control of roads and parking areas for industrial and public use.

The Gard series is available in the 230V A.C. motor and the 24V D.C. motor versions.

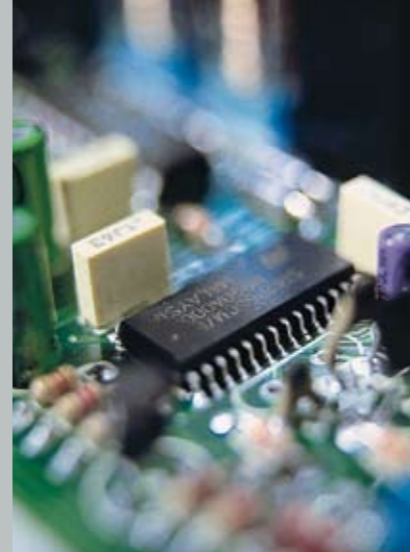

The 230V electronics

The Gard series barriers are constructed with next-generation electronics that guarantee total control of the automatic system, improving and increasing the usual safety and control functions, such as:

- > **Comprehensive AUTOTEST of all the safety devices**
connected to the system prior to activating the motor (electronic autotest).
- > **Electronic control of the movement**
of the bar with obstacles detection (anti-crushing function).
- > **Safety feature even when the bar is stationary**
all controls are invalidated if an obstacle is detected by the safety devices.

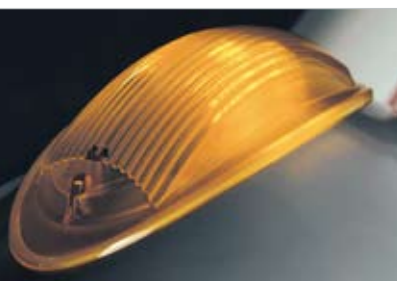

A blend of design and modern technology of illumination.

The exclusive incorporated flashing light with a lighted LED diffuser needs no special maintenance and ensures complete visibility of the warning light.



The protective guard on the bar is a standard feature.

Protects the user from possible risk when the bar is in rotation.



Perfectly integrable.

The safety photocells are applied directly onto the bar and integrate harmoniously and aesthetically with the system.

The new series offers many new features, all marked by innovation



Maximum safety.
An electronic contact automatically interrupts the power supply voltage as soon as the inspection door is opened.

Round tubular bar.
For maximum reduction of the sail effect ensuring correct functioning even in areas subject to high winds.

Command electronics.
Protected by a die-cast aluminium guard, it is positioned to make any type of intervention extremely practical.

Luminous cord.
Superior visibility of the arm and maximum durability of the light fixtures.

Differentiated sensitivity spring.
For exceptional balancing of the bar.

The advantages of 24V barriers



Streets, parking areas, collective areas or simply specific functional and security needs of the system can call for the use of a Gard system with 24V technology.

- > **Frequent blackouts**
The electronics of a Gard 24V system automatically recognizes a lack of power and activates emergency operation with special auxiliary batteries.
- > **Keep speed in check**
For total service, the 24V electronics enables the operating speed to be adjusted depending on whether the situation requires faster or slower openings and closings.
- > **Intensive traffic**
The low-voltage motor ensures operation of the barrier for intensive traffic conditions, such as streets, parking areas and other areas entailing constant, intensive operation.
- > **Rapid transit**
The 24V technology regulates the barrier opening time between 8 and 4 seconds.



Also available as a set or with synchronous action

Thanks to the additional RSE card the barriers can be installed facing each other or be synchronised with the "compass" function at the same access point.



Global entry control

The Gard series automatic barrier system can be connected to many of the Came access control systems that allow identification, memorization, and entry and exit only to authorized personnel. The equipment can also be integrated with a global access control system for specific departments in a company or the services offered by a collective structure and apartment blocks.

